

NOTES:

1. THIS IS A SUPPLEMENTAL DETAIL DRAWING, AND IS TO BE USED IN CONJUNCTION WITH 3D PART MODEL FILE TO MANUFACTURE AND INSPECT THE FABRICATED PART. IN CASE OF CONFLICT BETWEEN MODEL FILE AND A DIMENSION ON THIS DRAWING, THE DIMENSIONS WILL TAKE PRECEDENCE.
2. ALL FEATURES NOT DIMENSIONED ARE DERIVED FROM THE PART MODEL FILE DATABASE.
3. MATERIAL: PP Homopolymer
4. COLOUR: NATURAL
5. NO METALLIC CONTAMINATION PERMITTED.
6. TYPICAL DRAFT IS 1.0 DEG. SUBRACTIVE AS REQUIRED.
7. UNLESS OTHERWISE SPECIFIED, MAXIMUM PERMITTED RADIUS ON INTERNAL CORNERS, CORE SIDE, TO BE 0.2 [mm]
8. GATE(S) TO BE TRIMMED FLUSH OR BELOW SURFACE.
9. REMOVE FLASH AND DEBURR PART LINE.

LOCAL DEFORMATION OR BREAK-THROUGH ACCEPTABLE

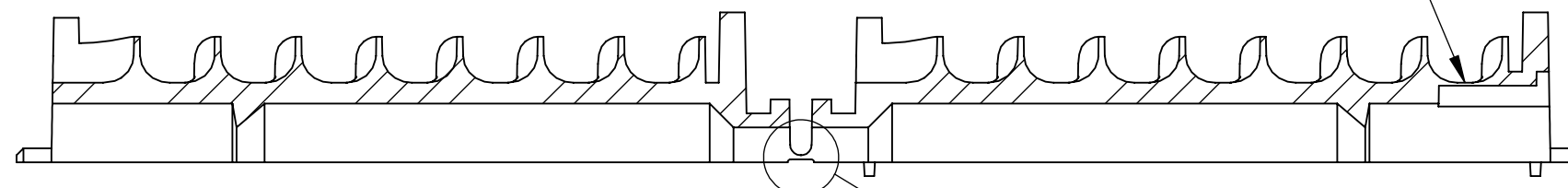

SECTION A-A B

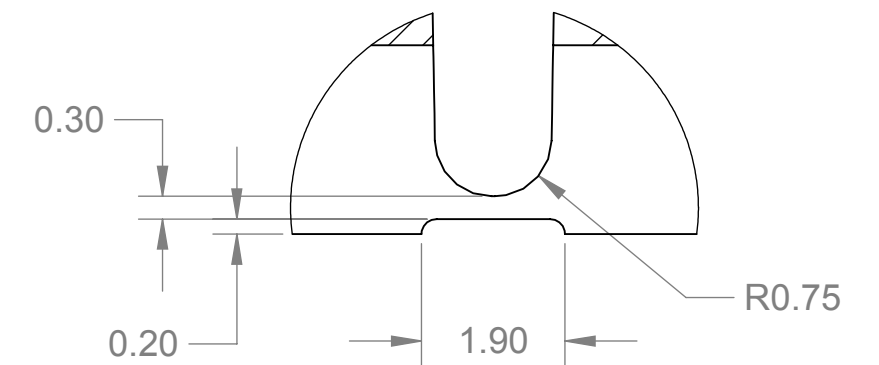

DETAIL B  
SCALE 10 : 1

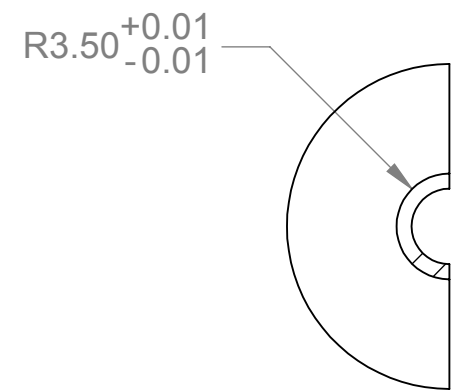

SECTION C-C

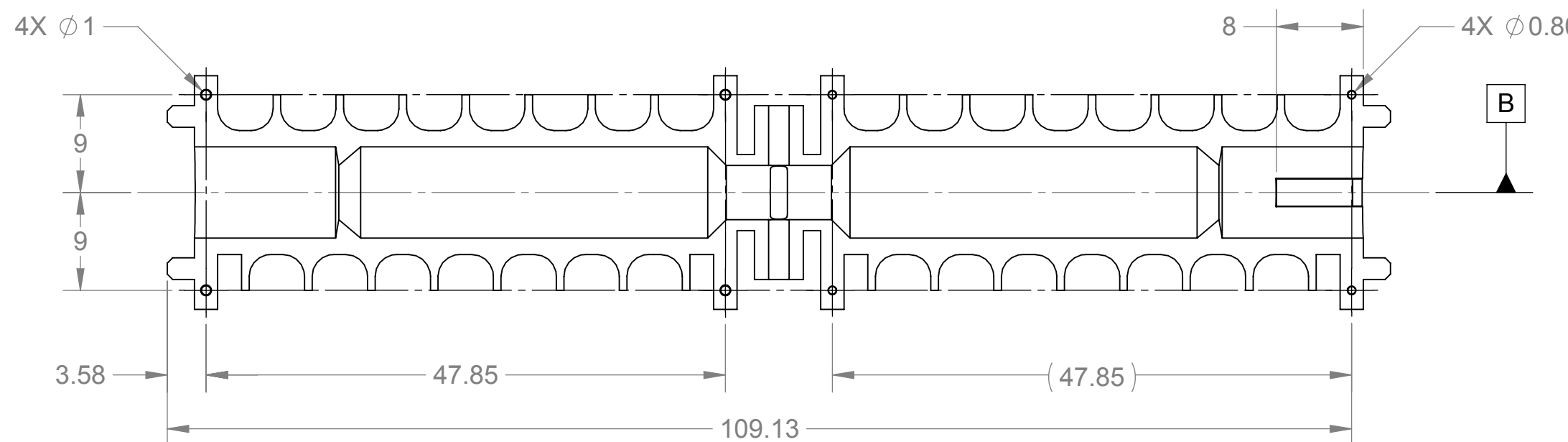
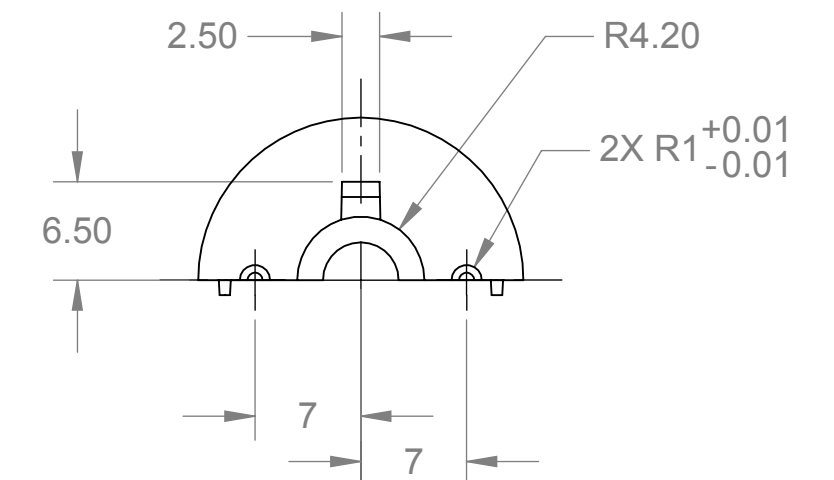
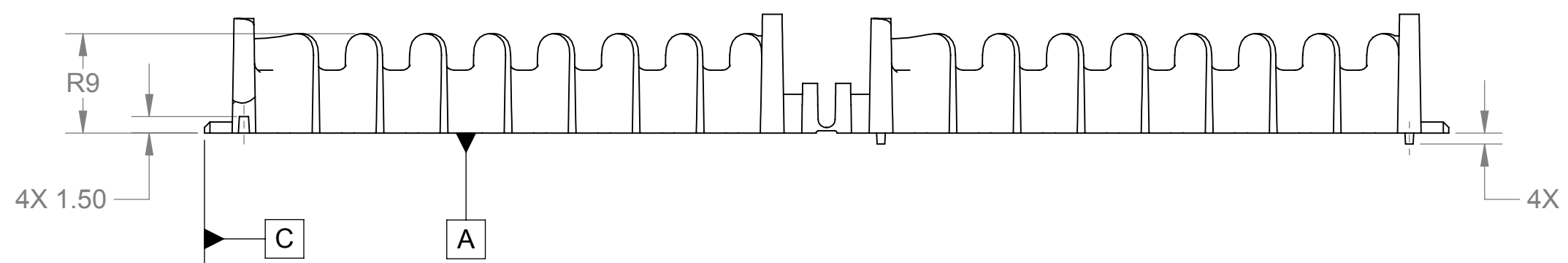
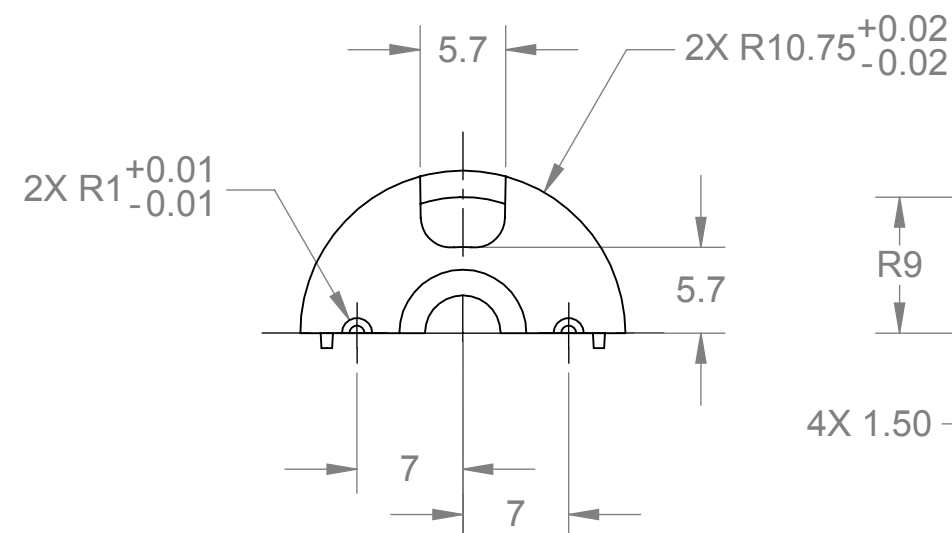
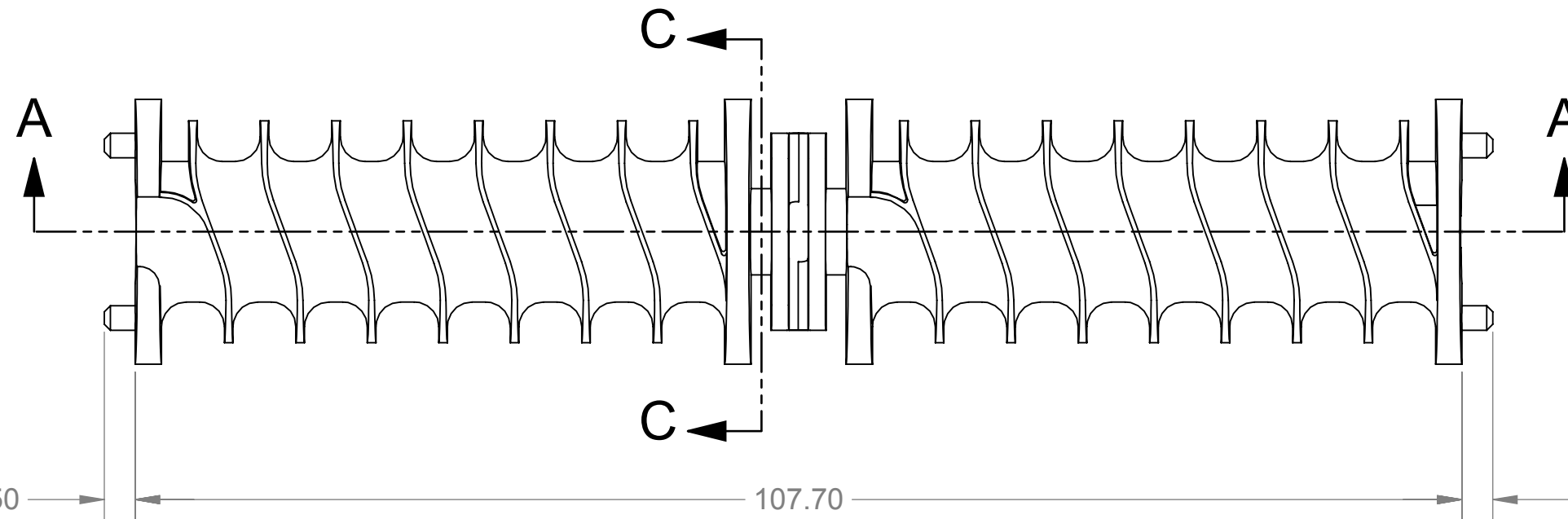

MATERIAL RESTRICTIONS: ALL PARTS AND ASSEMBLIES SUPPLIED TO THIS SPECIFICATION SHALL BE IN FULL COMPLIANCE WITH SM-0564 - MATERIAL PROHIBITIONS AND RESTRICTIONS.	
UNLESS OTHERWISE SPECIFIED THIS DOCUMENT CONTAINS PROPRIETARY DATA OF HOLOGIC INC. NO DISCLOSURE, REPRODUCTION, OR USE OF ANY PART THEREOF MAY BE MADE EXCEPT BY WRITTEN PERMISSION FROM HOLOGIC.	
DO NOT SCALE DRAWING INTERPRET IN ACCORDANCE WITH ASME Y14.5M-2009 DIMENSIONS ARE IN mm TOLERANCES APPLY AS SHOWN BELOW	
0-10 ± 0.1	10-50 ± 0.2
50-100 ± 0.3	100-300 ± 0.4
300-1000 ± 0.5	ANGLES ± 5°
SURFACE ROUGHNESS: 0.8 µm	
THIRD ANGLE PROJECTION	
NAME	DATE
ENGINEER: J. JANKOWSKI	
AUTHORED BY: J. JANKOWSKI	20JUN2011
DRAFTED BY: J. JANKOWSKI	20JUN2011
REVISION	RELEASE DATE

<b>HOLOGIC</b>		SENTINELLE MEDICAL A DIVISION OF HOLOGIC 555 RICHMOND STREET WEST TORONTO, ON M5V 3B1	
DESCRIPTION <b>BALUN CORE HELICAL MOLDED</b>			
PART/ASSEMBLY NUMBER: <b>FAB-07721</b>		DRAWING NUMBER: <b>FAB-07721</b>	
ENGINEER:	J. JANKOWSKI	DATE:	20JUN2011
AUTHORED BY:	J. JANKOWSKI	SCALE:	2:1
DRAFTED BY:	J. JANKOWSKI	MODEL FILENAME:	FAB-07721 - FAB BALUN CORE HELICAL MOLDED
REVISION		RELEASE DATE	
SIZE: <b>C</b>		REV: <b>0</b>	
SCALE: <b>2:1</b>		SHEET 1 OF 1	

CONFIDENTIAL

FOR QUOTATION ONLY