

NOTES:

1. PERMANENTLY MARK: TOP LEVEL PART NUMBER WITH REVISION, VENDOR CODE AND DATE CODE USING 3mm MAX. HIGH CHARACTERS, APPROXIMATELY WHERE SHOWN. IF NOT SHOWN PARTS ARE TO BE BAGGED AND LABELED
2. THIS PART DESIGNED FOR FABRICATION USING ELECTRONIC GRAPHIC INTERCHANGE (3D CAD DATA FILES) AND SUPPLIERS FABRICATING THIS PART MUST RECEIVE THE ELECTRONIC PART FILES FROM HOLOGIC. THIS DETAIL DRAWING IS TO BE USED IN CONJUNCTION WITH THE 3D CAD MODEL FILE TO MANUFACTURE AND INSPECT THE FABRICATED PART. IF THE CAD MODEL FILE AND DRAWING CONFLICT, THE DRAWING, WILL TAKE PRECEDENCE.
3. ALL FEATURES NOT DIMENSIONED ARE DERIVED FROM THE PART MODEL FILE DATABASE AND ORIGINATE FROM THE PRIMARY DATUM PLANES, UNLESS OTHERWISE SPECIFIED. UNLESS OTHERWISE NOTED ON THE DRAWING, THE FABRICATED PART SHALL MATCH THE ELECTRONIC MODEL TO THE FOLLOWING TOLERANCES:
  - 3.1. FOR DIMENSIONS LESS THAN OR EQUAL TO 125 mm +/- 0.13 mm
  - 3.2. GREATER THAN 125 mm +/- 0.03 mm PER 25 mm
  - 3.3. ANGULAR TOLERANCES; +/- 0.5°
4. MATERIAL: SABIC LEXAN 940A POLYCARBONATE. COLOR TO MATCH RAL 9010. NO REGRIND ALLOWED. NO METALLIC CONTAMINATION IS PERMITTED. CERTIFICATE OF COMPLIANCE MUST BE PROVIDED AT TIME OF SHIPMENT.
5. FINISH: ALL EXTERIOR SURFACES TO BE TEXTURED - MT-11020 (LIGHT TEXTURE). ALL OTHER SURFACE SPI B-3
6. TOOL CONSTRUCTION, GATE, EJECTOR PIN, AND ANY TOOL INSERTS WITNESS LINES TO BE APPROVED BY HOLOGIC.
7. GATE MARKS AND PARTING LINE FLASH TO BE REMOVED TO WITHIN 0.25 mm OF SURFACE. NO SHARP EDGES REMAINING AFTER THE GATE(S) ARE REMOVED (MAX. FINISH 64RMS)
8. DIMENSIONS INDICATED WITH A (XX) SYMBOL ARE CRITICAL TO FIT AND FUNCTION.

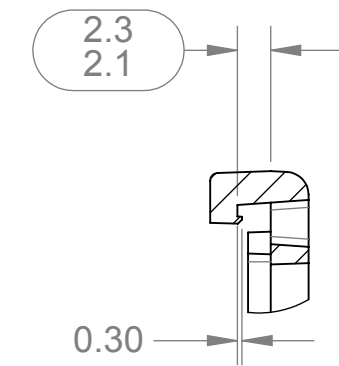
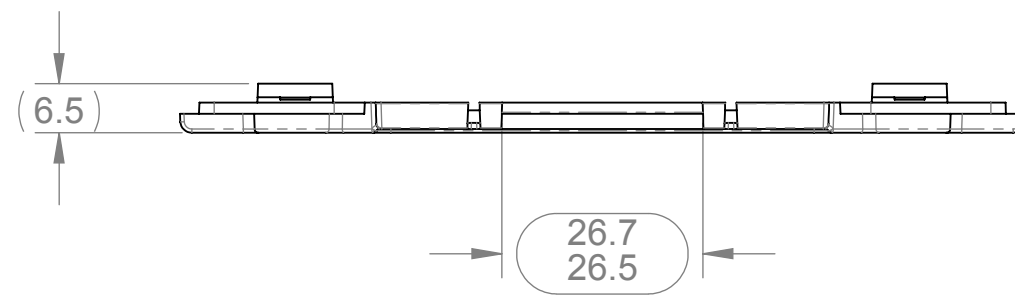
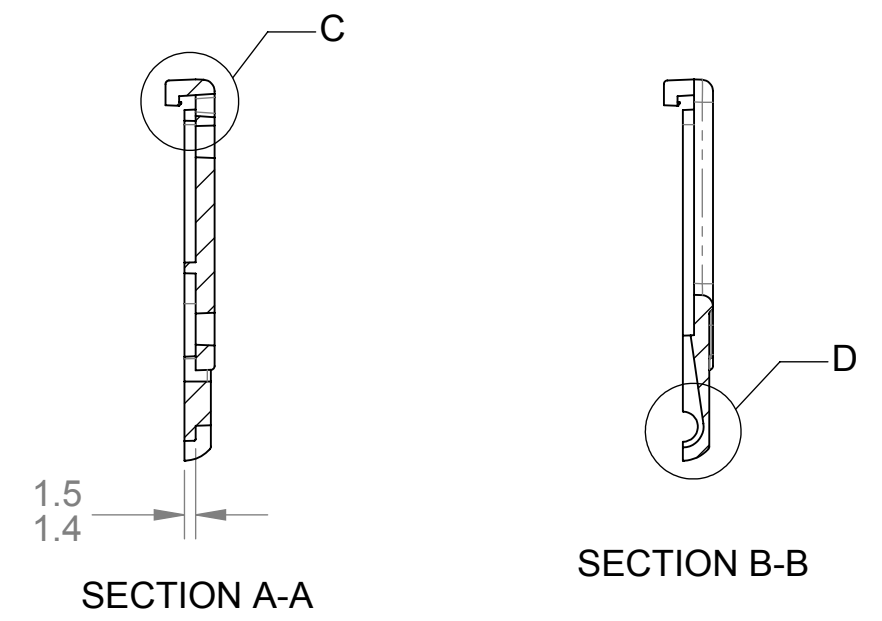
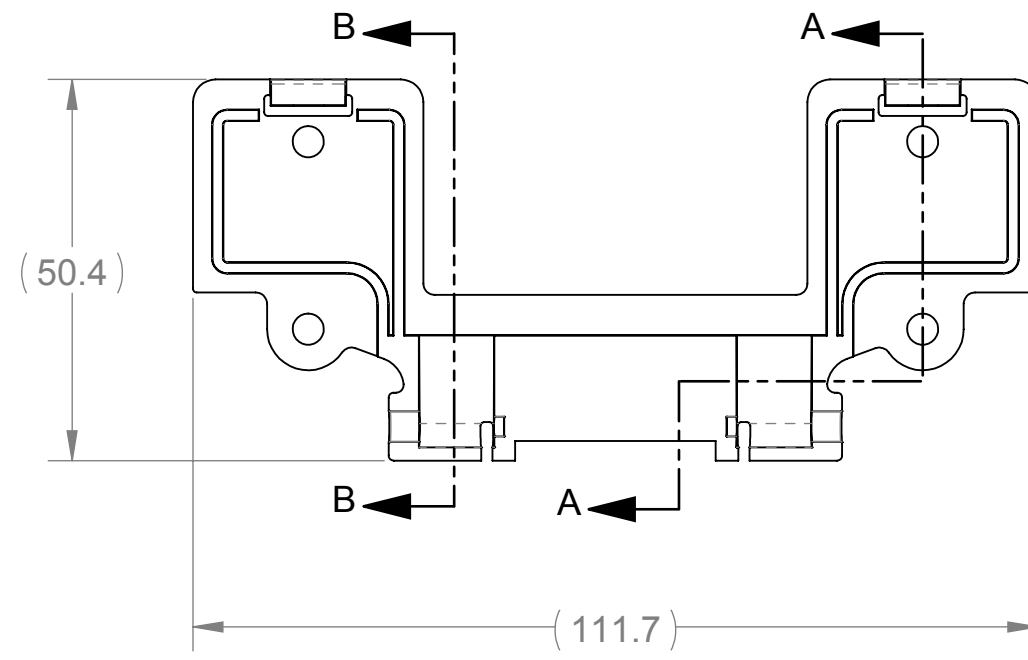

DETAIL C  
SCALE 2 : 1  
2 PLACES

ALL TANGENT FACES 5

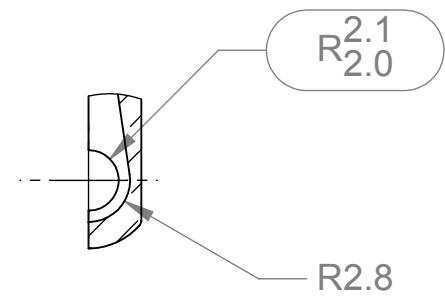
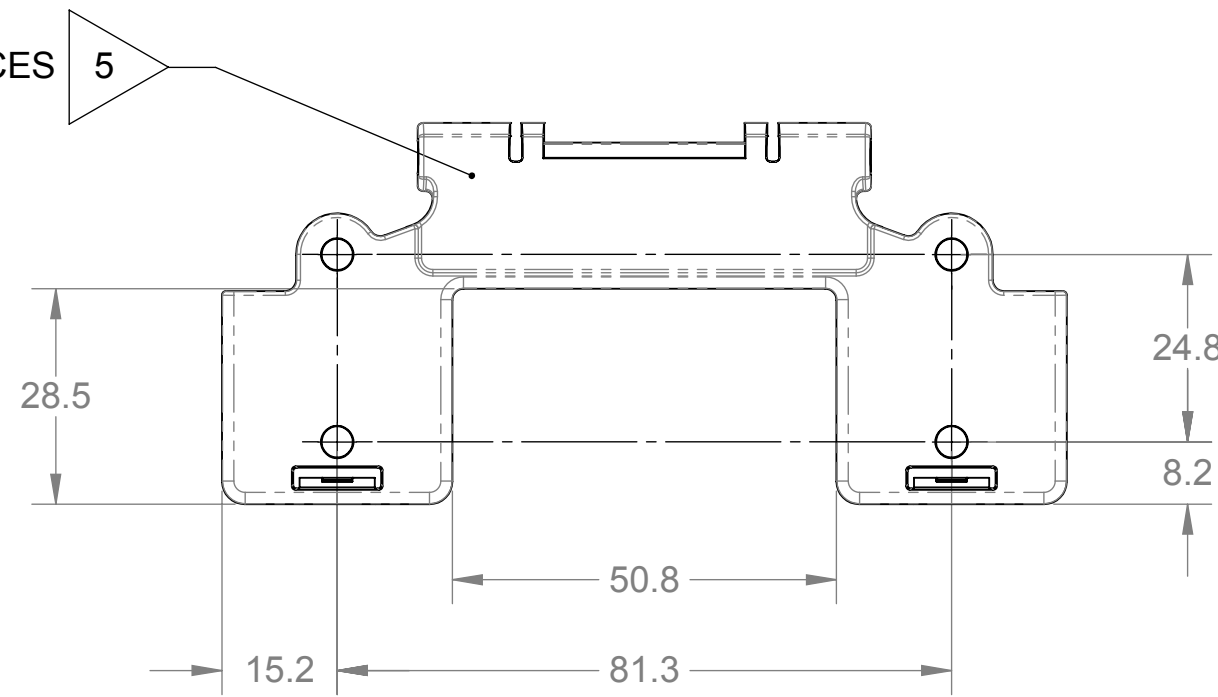

DETAIL D  
SCALE 2 : 1  
2 PLACES

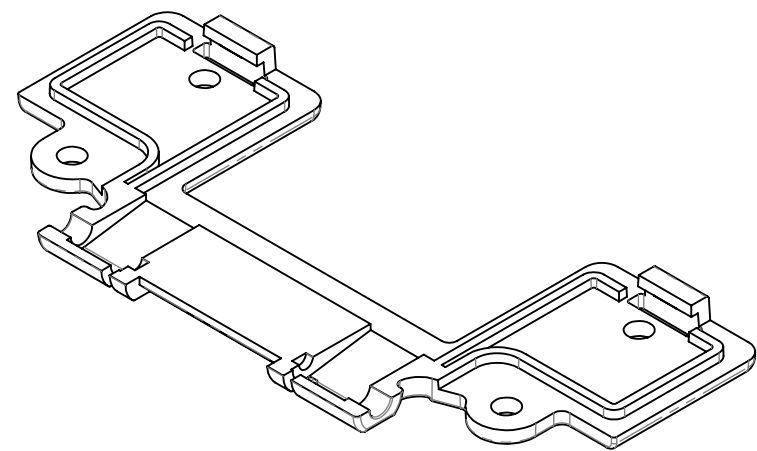

CONFIDENTIAL

MATERIAL RESTRICTIONS: ALL PARTS AND ASSEMBLIES SUPPLIED TO THIS SPECIFICATION SHALL BE IN FULL COMPLIANCE WITH SM-0564 - MATERIAL PROHIBITIONS AND RESTRICTIONS.		THIS DOCUMENT CONTAINS PROPRIETARY DATA OF HOLOGIC INC. NO DISCLOSURE, REPRODUCTION, OR USE OF ANY PART THEREOF MAY BE MADE EXCEPT BY WRITTEN PERMISSION FROM HOLOGIC.		<b>HOLOGIC</b> SENTINELLE MEDICAL A DIVISION OF HOLOGIC 555 RICHMOND STREET WEST TORONTO, ON M5V 3B1	
UNLESS OTHERWISE SPECIFIED DO NOT SCALE DRAWING INTERPRET IN ACCORDANCE WITH ASME Y14.5M-2009 DIMENSIONS ARE IN mm TOLERANCES APPLY AS SHOWN BELOW FOR DIMENSIONS LESS THAN OR EQUAL TO 125 mm +/- 0.13 mm GREATER THAN 125 mm +/- 0.03 mm PER 25 mm ANGULAR TOLERANCES +/- 0.5°		<b>PROPOSED</b>		DESCRIPTION <b>MOUNT TOP MEDIAL CONNECTOR COVER</b>	
THIRD ANGLE PROJECTION		NAME: J. JANKOWSKI DATE: N/A ENGINEER: J. JANKOWSKI AUTHORIZED BY: J. JANKOWSKI DRAFTED BY: J. JANKOWSKI REVISION RELEASE DATE:		PART/ASSEMBLY NUMBER: <b>FAB-12327</b>	
		SIZE: C SCALE: 1:1		DRAWING NUMBER: <b>FAB-12327</b> REV: 001.1	
		MODEL FILENAME: FAB-12327 - MOUNT TOP MEDIAL CONNECTOR COVER		SHEET 1 OF 1	